

PHOENIX EDGE ERROR CODES

TONE	MEANING	TONE	MEANING
• -	Low voltage cutoff	• • -	Radio glitch
• - •	Over temperature	• • •	Motor anomaly
• - -	Excessive load	- •	Over-current
• •	Start fail	- • •	Auxiliary Wire Radio Glitch

DEFAULT SETTINGS

OPTION	SETTING	OPTION	SETTING
Auto-LiPo Volts/Cell	3.2 Volts/Cell	Motor Start Power	Medium 59
BEC Voltage	5.0V	Motor Timing	Normal 5
Brake Delay	0.6 sec (Delayed)	PWM Rate	12 Khz
Brake Ramp	Immediate	Throttle Type	Auto-Calibrate Endpoints
Brake Strength	Disabled		
Current Cutoff Type	Soft Cutoff	Vehicle Type	Airplane
Current Limiting	Normal	Voltage Cutoff Type	Soft Cutoff
Cutoff Voltage	Auto-LiPo	Auxiliary Wire	Disabled
Direction	Forward	Link Live	Disabled

CLEARING THE DATA LOG

Power your controller up with your TX and RX on and set to full throttle. The controller will chime the normal power up chimes. Leave your TX at full throttle for 6 seconds after power up. The controller will emit a short tone after 1 second and then a long tone 5 seconds later. The controller will then erase the data log. You must then move the throttle stick to lowest power to arm the controller.

PHOENIX EDGE 100 ESC

APPLICATIONS

Helis: 500, 550, or 600 Class (use external BEC or RX/servo power source; not included)
Fixed wing: .40 - .90

TECHNICAL SPECIFICATIONS

Input voltage:	MIN: 2S LiPo MAX: 8S LiPo
Max continuous amperage at full throttle:	100 amps*
BEC voltage (voltage regulator for powering radio and servos):	User selectable choice from 5 to 8.4 volt output
BEC output amperage:	5 amp peak**
Dimensions:	Width: 2.0" (50.8mm) Length: 2.8" (71.9mm) Depth: 0.9" (23.2mm)
Weight with wires:	4.5 oz (126.6 g)
Weight without wires:	2.6 oz (72.9 g)

ITEMS NEEDED FOR OPERATION OR INSTALLATION

Programmability:	A wide range of ESC settings may be programmed via computer with a Castle Link USB adapter (sold separately), a Windows PC and the free Castle Link software available at https://home.castlecreations.com/download-castle-link . You may also program with a mobile device (iOS or Android) using a Castle B-Link Bluetooth Adapter (sold separately).
Connectors:	Battery and motor connectors sold separately
Tools needed for installation:	Soldering iron and solder to attach bullets to motor wires and battery connector to power wires.

*RC HOBBY APPLICATION RATING: 100 amps for the duration of a single 10,000 mAh battery pack with the ESC in contact with a 5 mph airflow of 25C (77F) or cooler air. Controller temperature must never exceed 100C (212F). Exceeding current or temperature ratings may damage components and may shorten the life of the ESC. Always verify system current draw at full-throttle. Decrease load or increase airflow to decrease the ESC's operating temperature.

**Peak indicates amperage sustainable for 0.5 seconds - long enough for most servos' current draw transients. Your setup may vary. Always confirm servo current draw before the first flight of the model.



castlecreations.com

U.S. Patent # 7400103, 7492122, 7579796, 7740516, 8287328, and 8678875 - other patents pending.

Product designed and assembled in Olathe, Kansas USA.

This product may contain chemicals known to the State of California to cause cancer and/or birth defects or other reproductive harm.

© 2025 CASTLE CREATIONS

PKG: 095-0437-01



P/N: 010-0100-00



8 19326 01002 6

REVISION DATE: 05/2025

PHOENIX
EDGE
100
 BRUSHLESS SPEED CONTROL



OVERPOWERING RC SINCE 1997

castle

PHOENIX EDGE WIRING GUIDE



PLEASE READ FOR IMPORTANT WARNINGS AND UPDATES

WIRING YOUR EDGE ESC

When adding an external BEC* to your Edge you must make sure that the negative BEC lead is connected directly to the negative lead on your Edge ESC. Failure to properly wire the BEC can cause ESC failure. We recommend wiring the BEC like the diagram below due to the fact that the lower BEC input voltage will allow higher continuous current loads. Another advantage is that the lower battery pack can be connected before the upper pack to allow your receiver to power-up and bind before the Edge ESC is even powered. The Edge ESC contains an internal BEC, if an external BEC is needed then the RED wire on the servo lead must be disconnected.

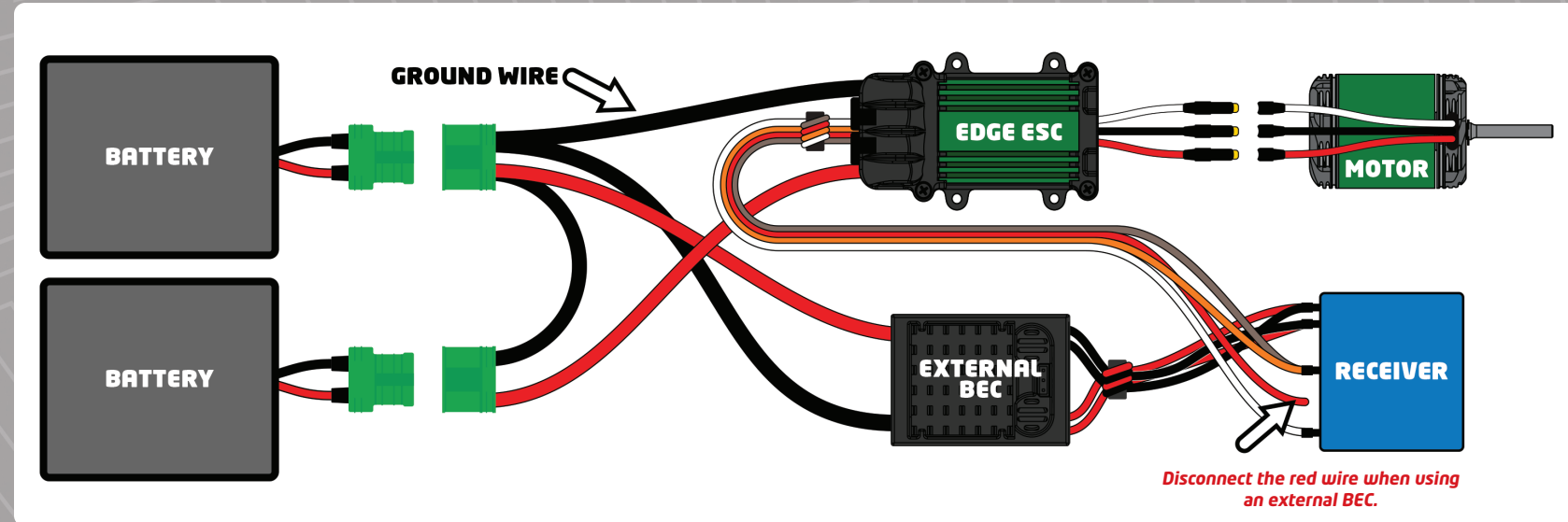

*An external BEC is recommended for helicopter classes larger than 450.

ALTERNATIVE WIRING

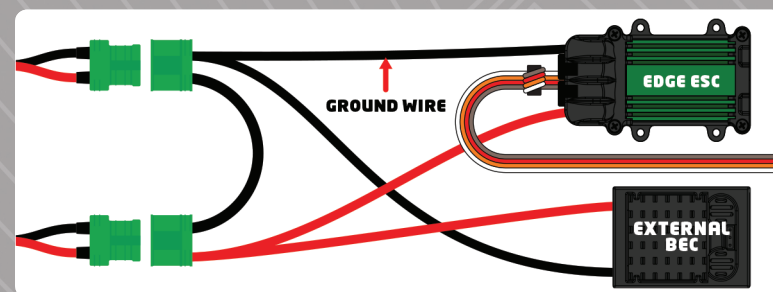

The **ground wire** on the Edge and the BEC **must** be connected.

IMPROPER WIRING

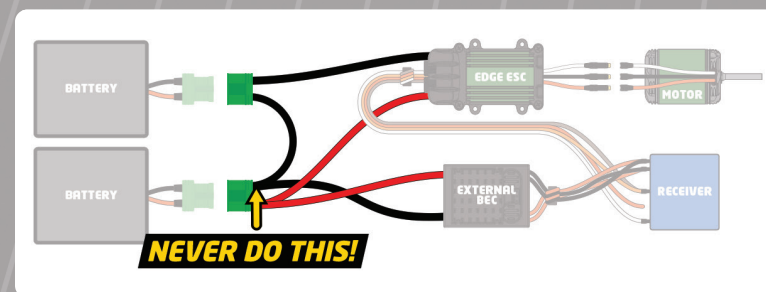

DO NOT wire your BEC like the diagram above. Wiring the BEC to a ground lead other than the Edge's ground could lead to ESC failure.

OPTIONAL STICK PROGRAMMING

1. Power ESC with TX throttle stick (stick) in the top position (full throttle). LED will repeat a quick single flash.
2. Move stick to the middle. Phoenix Edge will emit a short tone, and LED repeats a quick double flash. Repeat high / medium through to a triple flash.
3. ESC sounds four short tones, and the LED will repeat a long single flash.
4. Step through settings and values by answering "yes" (full throttle) or "no" (low throttle). The setting and value are "flashed" out by the LED. Example: setting #3 value #2, = 3 beeps/flushes, then 2 beeps/flushes. Answering "no" moves to the next value. A "yes" answer is signaled by rapid LED flashes and a constant beep.
5. Move the stick to the middle position to move to next setting. Repeat steps 4 and 5 as needed.
6. Once the desired settings are entered, remove and reconnect power. Arm speed control as normal.

Stick programming offers quick access to basic settings only. Many more may be accessed using Castle Link and a Windows PC.

SETTING 1: LV CUTOFF BATTERY CELL CUTOFF VOLTAGE*

Option 1:	3.0V per cell	Option 4:	3.3V per cell
Option 2:	3.1V per cell	Option 5:	3.4V per cell
Option 3:	3.2V per cell (FS)	Option 6:	DISABLED

SETTING 2: BRAKE TYPE

Option 1:	Soft Delayed Brake	Option 4:	Hard Brake - No Delay
Option 2:	Hard Delayed Brake	Option 5:	Brake Disabled (FS)
Option 3:	Soft Brake - No Delay		

SETTING 3: LV CUTOFF TYPE

Option 1:	Hard Cutoff	Option 3:	RPM decrease
Option 2:	Soft Cutoff (FS)	Option 4:	Pulsing RPM ESC pulses throttle

SETTING 4: PWM SWITCHING RATE**

Option 1:	8kHz outrunners	Option 3:	16 kHz
Option 2:	12 kHz (FS)		

Note: (FS) = factory setting; LV stands for low voltage.

*Refer to cell vendor's instructions for cutoff voltage.

**Refer to motor manufacturer's instructions for frequency settings.

Continued on the next panel.